

AGRONIC[®]

Made in Finland

Agronic XS – Serie Slurry Tankers 2017



XS – A Single Axle Slurry Tanker

- A tanker equipped with a hydraulic bilge pump, no PTO shaft.
- Maneuverable, lightweight, and affordable tanker.
- A variety of spreading ramps and pumping arms are available.
- Top fill tanker with filling funnel
- Funnel descends 50cm into the tanker, no hatch needed.
- Hydraulic gate valve as standard
- Injector brackets are standard.
- LED light kit.
- Lacquered paint.
- Available Sizes: 10m³ & 12m³



Excellent handling characteristics through careful design.

- Overall low centre-of-gravity, with tank attached directly to the axle.
- Tank has an oval shape.
- Design allows for the front to emptied last, to maintain proper weight distribution.
- Fitted with two baffles inside.
- High quality radial tires.

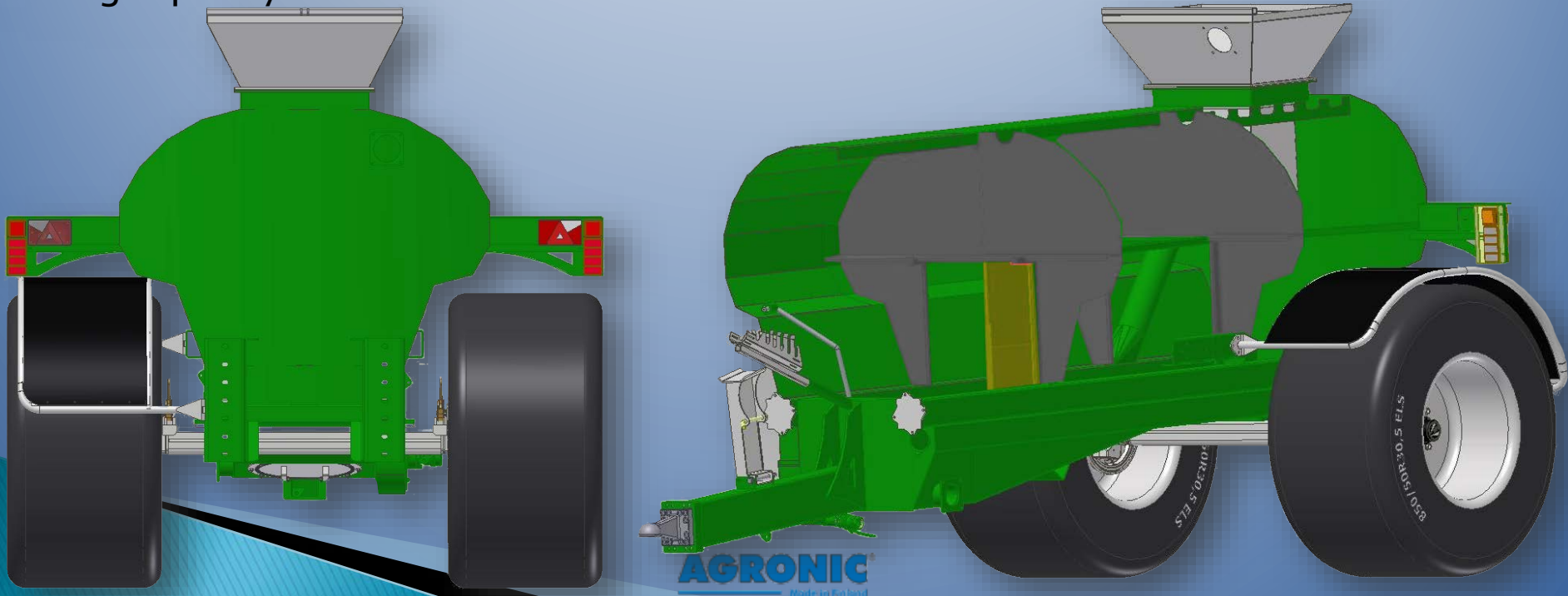

Three Tire Sizes, & Crab Steering as an Option.

Axles sourced from ADR, fitted with hydraulic brakes.

Tire sizes are: 850/50R30,5, 900/60R32 or 1050/50R32

Tanker has a maximum width of 328 cm.

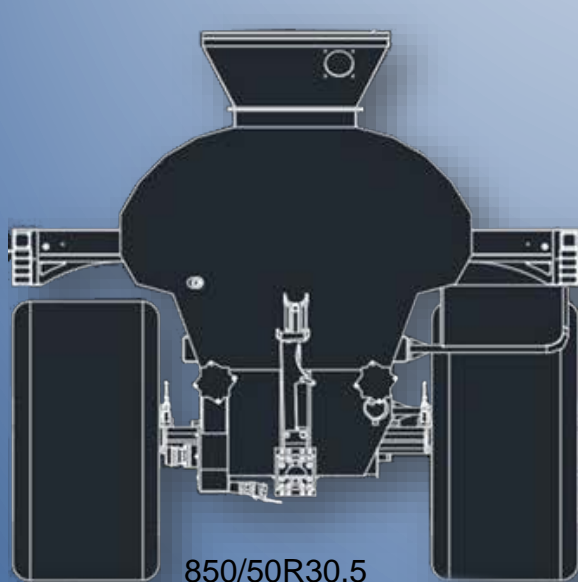

850/50R30,5
With or without Crab
Steering

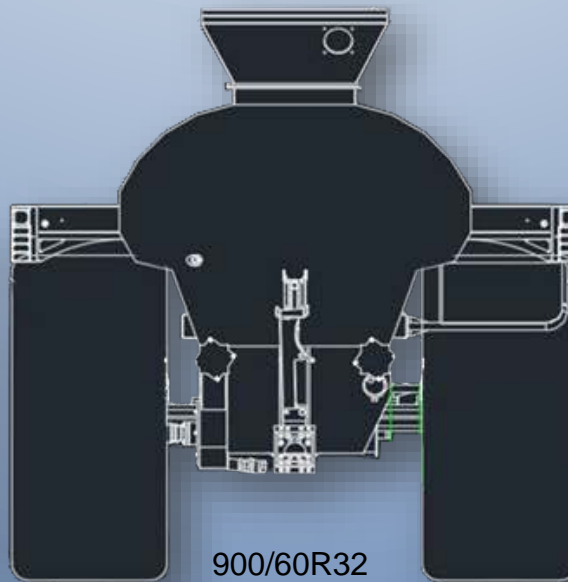

900/60R32
Only with
Crab Steering

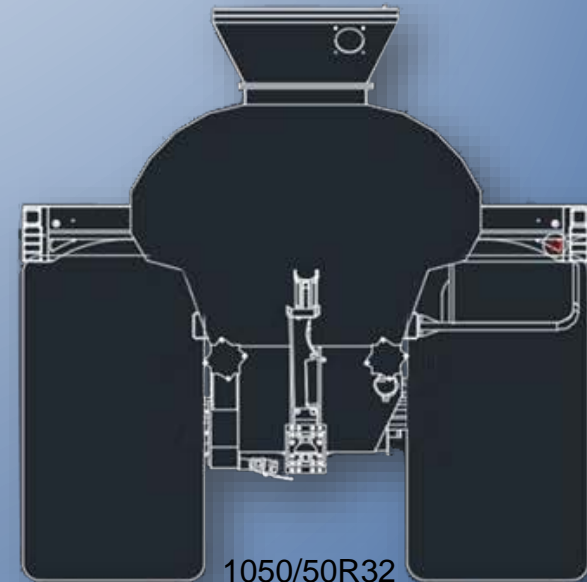

1050/50R32
No Crab Steering

The two Biggest Tires with a Tractor Tread Pattern.

Tire Dimensions:

800/50R30,5 Nokian ELS steel belt diam. 1625 mm, width 862 mm.

For use with or without crab steering.

900/60R32 BKT AgriMax Teris, diam. 1893 mm, width 886 mm.

For use with only with crab steering.

1050/50R32 BKT AgriMax Teris, diam. 1893 mm width 1059 mm.

Not available fo use with crab steering systems.



Compact Size

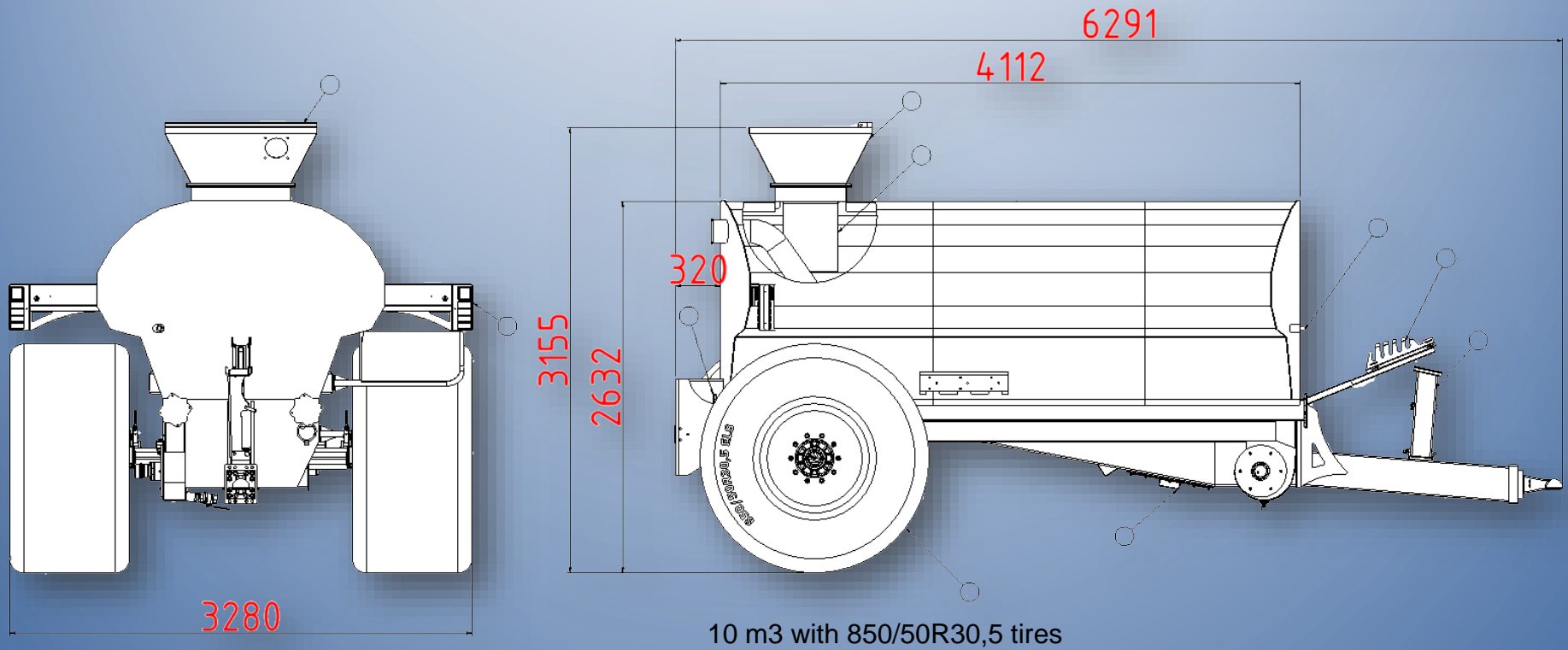



10.000L **AGRONIC**

Xs

65 R 38

AGRONIC
Xs
10.000L

AGRONIC

AGRONIC